

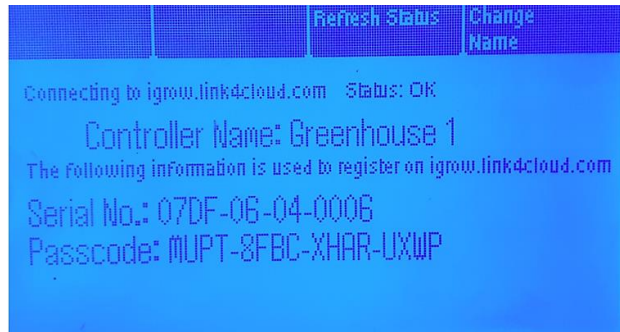

To get your controller connected with the **iGrow 800 Cloud** and to have it viewable via PC, Smartphone, Tablet or any device with internet browser capabilities.

You would first need to run an Ethernet connection to the controller and plug it into the communication module

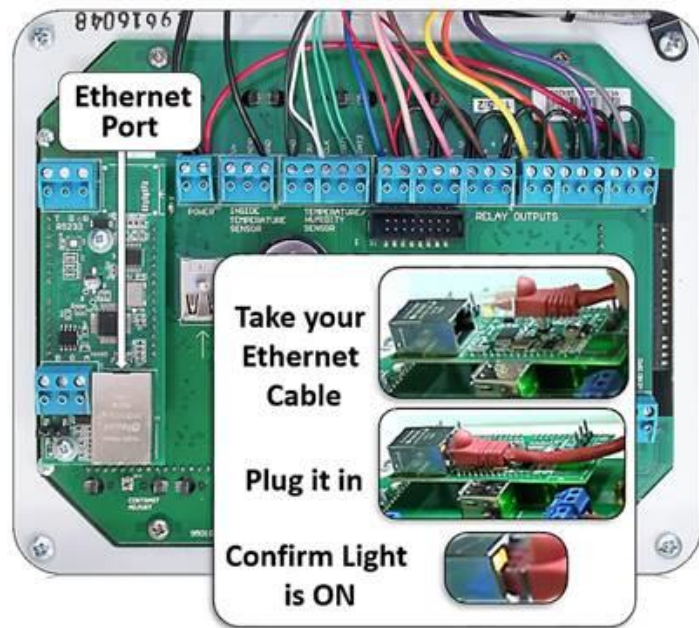

Once you're connected to the Internet, the controller will automatically link up to the **Link4 Cloud Server** (igrow.link4cloud.com) and the Cloud Setup Screen connection status will display **"Check Account"**.

Once you add your controller on the iGrow Cloud the connection status will display **OK**.

Use the instructions below to access the controllers serial number and registration passcode which you will need in order to add your controller to the iGrow Cloud.

- From the Main Menu, Press **Soft Button No. 3** or use the **Navigation Menu** to highlight **System Setup**
- Press **Soft Button No. 10** or use **Navigation Menu** to highlight **Communication Setup**
- Press **Soft Button No. 2** or use **Navigation Menu** to highlight **Cloud Setup**
- View your **Serial Number** and **Registration Passcode**

Next go to the Browser on your computer or mobile phone and visit the **iGrow Cloud** igrow.link4cloud.com
If you haven't done so already, please create an account.

To set up your controller for remote access through your computer or smartphone, please follow the three (3) easy steps below:



Step 1 – Log in to your Link4 Account and click on my iGrow cloud.

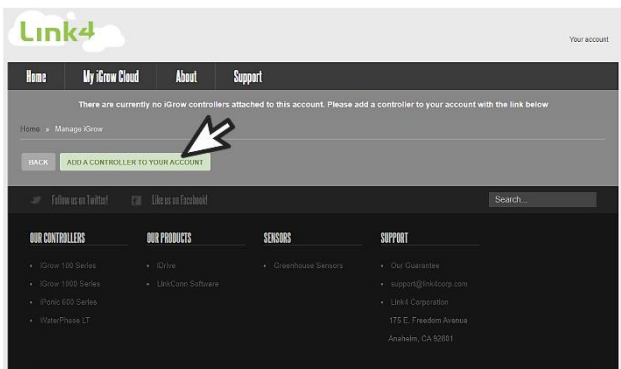

Step 2 – Click on Add a controller to your account

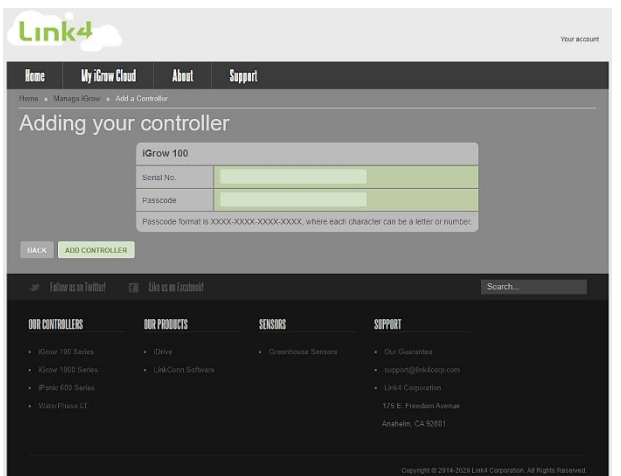

Step 3 – Enter the Serial Number, Registration Passcode and select ADD CONTROLLER

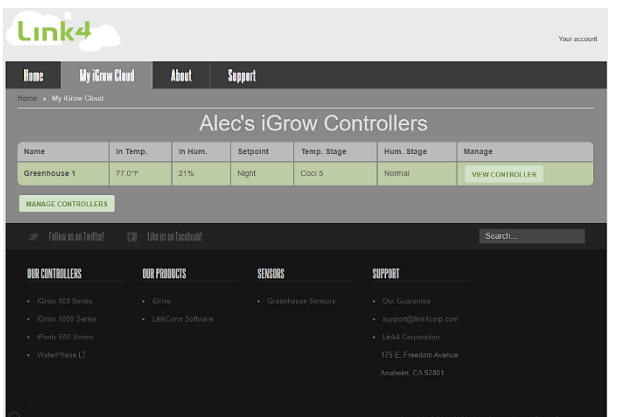

Congratulations! You can now remotely access your controller through your computer or smartphone.

Please see attached video for additional training

If you have any questions please call us at 714-975-9474